



725 SOUTH LA CADENA DRIVE COLTON CA 92324

909.291.7550

www.cbmmotorsports.com

LS RED/BLUE ECU

Connector:	Description:	Wire colors:
Diagnostic data	OBD II port	orange, green, black, black
Crank sensor 24x	3 pin black w/blue seal	green, yellow w/black stripe, blue w/white stripe
Knock sensor	2 pin black w/blue seal	lt. blue, dk. blue
Ignition coils	7 pin white w/orange seal	black, purple, pink, red, green, brown, lt blue <i>(even side white stripe, odd side solid)</i>
Air temp OR MAF sensor	2 pin grey w/blue seal 5 pin black w/purple seal	purple, tan purple, tan, black, pink, yellow
Injectors	2 pin black	pink, red/black (7) pink, black/white (5) pink, pink/black (3) pink, black (1) pink, green/black (2) pink, dk blue(4) pink, yellow/black (6) pink, dk blue/white (8)
Cam sensor	3 pin black w/purple seal	red, pink w/black stripe, brown w/white stripe
MAP	3 pin grey w/blue seal	grey, green, orange w/black stripe
Coolant temp	2 pin black w/blue seal	yellow, black
Alternator	4 pin black w/orange seal	pink
O2 sensors (optional)	4 pin black square w/blue seal	tan, black, pink, purple <i>(odd side white stripe, even side solid)</i>
TPS	3 pin black w/purple <i>(round)</i>	grey, black, blue



725 SOUTH LA CADENA DRIVE COLTON CA 92324
 909.291.7550
 www.cbmmotorsports.com

LS RED/BLUE ECU cont.

Connector:	Description:	Wire colors:
IAC	4 pin w/blue seal	dk green w/black stripe, lt green w/white stripe, dk blue, lt blue w/white stripe
Ground	7 wire ring terminal	black, black w/white stripe
Transmission main plug	20 pin grey	uses 11 wires
Transmission vehicle speed sensor	2 pin black w/blue seal	green, purple

Blunt cut wires*

Temp sender	Coolant temp gauge	yellow
Pressure sender	Oil pressure gauge	Brown

*These wires are provided for convenience only and do not need to be connected for the operation of our system. If your application uses analog gauges, simply connect the end of this wire to the sender. At the opposite end of the harness (*by the relay pack*) you will find the other end of the like colored wire. Connect this side directly to the gauge. This allows a clean installation without having to run additional wires through the harness. If you do not connect the harness end to a sender the gauges will not receive a signal and will display a zero value.

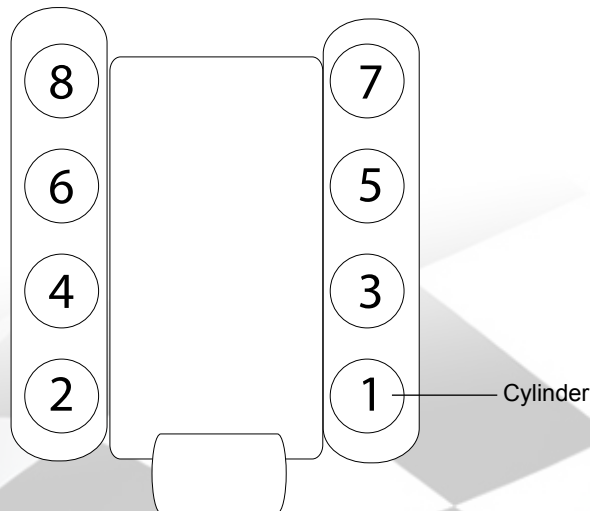

FRONT OF ENGINE

*FOR OFF-ROAD RACING ONLY, NOT FOR SALE IN CALIFORNIA FOR CA REGISTERED VEHICLES, NOT FOR USE IN CALIFORNIA.
 ** FOR SALE IN CALIFORNIA, FOR CA REGISTERED VEHICLES - APPROVED AND CERTIFIED BY CA RESOURCES BOARD.